

## SCB-100 100-Pin Shielded Connector Block

This guide describes how to connect and use the SCB-100 100-pin shielded connector block with 100-pin data acquisition (DAQ) products.

### Introduction

The SCB-100 100-pin shielded connector block is a shielded board with 100 screw terminals that connect to the AT-MIO-64E-3, AT-MIO-16DE-10, or other products using the 0.050 series shielded D type I/O connector.

The terminal block has 100 screw terminals for easy connection to signal wires. A cold-junction compensation temperature sensor is included for use with thermocouples. When the SCB-100 100-pin shielded connector block is used with other 100-pin products, bypass the accessories (the cold junction compensation temperature sensor and the signal accessory power LED) using the six switches, leaving a generic 100-screw terminal connector block. The SCB-100 also has a strain-relief bar for securing signal wires or cables.

### What You Need to Get Started

- SCB-100 100-pin shielded connector block kit
  - SCB-100 100-pin shielded connector block
  - SCB-100 quick reference label
  - SCB-100 100-Pin Shielded Connector Block Installation Guide*
- 100-pin cable (SH100100)
- 100-pin board
- Philips-head #1 and #2 screwdrivers
- 0.125 in. flathead screwdriver
- Long-nose pliers
- Wire cutters
- Wire insulation strippers
- Soldering iron and solder
- Resistors and capacitors (specific to your application)

## Switch Settings and Temperature Sensor Configuration

To accommodate thermocouples, the SCB-100 100-pin shielded connector block has a temperature sensor for cold-junction compensation. To power the temperature sensor, switches S1, S2, and S3 must be on as shown in Figures 1, 2, and 3. Notice that this also causes the signal accessory power LED to be on. You can configure the temperature sensor in the following three ways:

- To disable the cold-junction compensation temperature sensor so all analog channels are available, switches S4, S5, and S6 should be in the down position as shown in Figure 1.

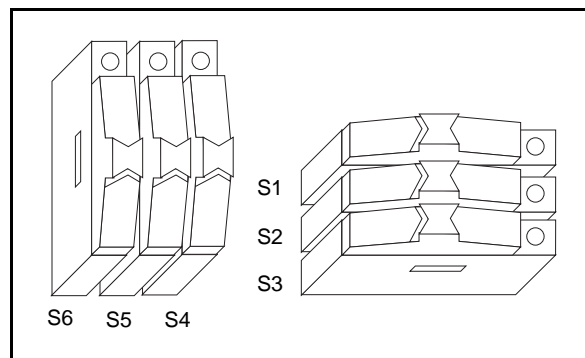

Figure 1. Disabled Temperature Sensor Switch Configuration with Accessory Grounds Connected

- For single-ended operation, connect the analog channel 0 to the temperature sensor by switching S5 to the up position, as shown in Figure 2. The signal is referenced to analog input ground (AIGND).

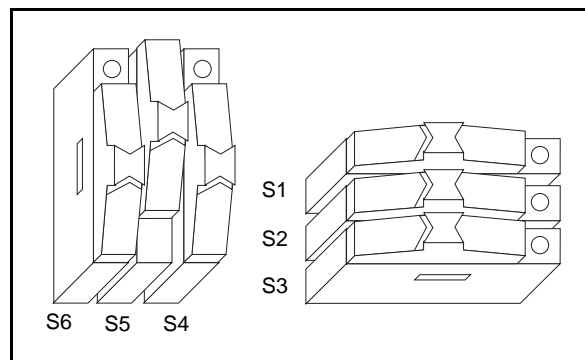

Figure 2. Single-Ended Temperature Sensor Switch Configuration with Accessory Grounds Connected

- For differential operation, connect the analog channel 0 to the temperature sensor by switching S5 and S4 to the up position, as shown in Figure 3.

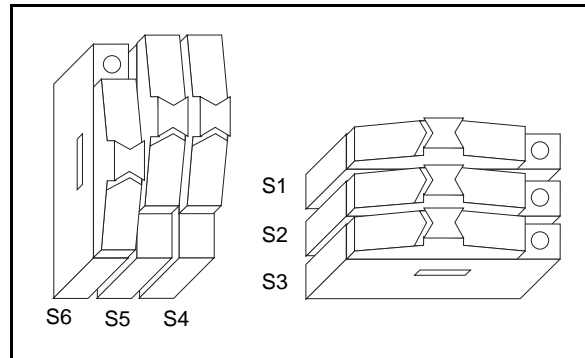

Figure 3. Differential Temperature Sensor Switch Configuration with Accessory Grounds Connected

- For use with any 100-pin board, bypass all circuitry by switching S6 to the up position, as shown in Figure 4. The LED will not light in this configuration.

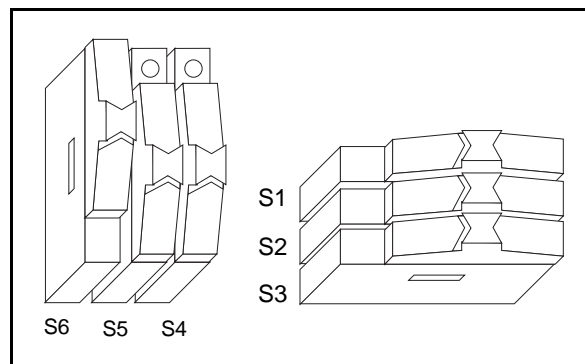

Figure 4. 100 Generic Screw Terminals Switch Configuration with Temperature Sensor and Accessory Grounds Disconnected

## Temperature Sensor Output and Accuracy

The SCB-100 temperature sensor outputs 10 mV/°C and has an accuracy of ±0.5° C.

You can also determine the temperature using the following formulas:

$$T_C = 100 * V_t$$

$$T_K = T_C + 273.15$$

$$T_F = \left[ \frac{9}{5} * T_C \right] + 32$$

where  $V_t$  is the temperature sensor output voltage;  $T_K$  is the temperature in Kelvin;  $T_F$  and  $T_C$  are the temperature readings in degrees Fahrenheit and degrees Celsius, respectively.

**Note:** *Use the average of a large number of samples to obtain the most accurate reading. Noisy environments require averaging more samples for greater accuracy.*

## Quick Reference Label

A quick reference label is included to show switch configurations and define screw terminal pinouts for the AT-MIO-64E-3 and AT-MIO-16DE-10. Place it on the connector block's inside cover for quick reference.

## Specifications

This section lists the SCB-100 specifications. These ratings are typical at 25° C unless otherwise stated.

### General

Number of screw terminals	101 (includes one no connect). All I/O signals are available at screw terminals
Cold-junction sensor	
Accuracy	±0.5° C
Output	10 mV/° C

### Power Requirement

Power consumption (at +5 VDC ±5%)	
Typical	10 mA with no signal conditioning installed

**Note:** *Limit the current drawn from the host computer's +5 VDC to about 800 mA, maximum.*

## Physical

Box dimensions (including feet)	19.6 by 15.2 by 4.6 cm. (7.7 by 6.0 by 1.8 in.)
I/O connectors type	One 100-pin male 0.050 series shielded D connector

## Operating Environment

Component temperature	0° to 70° C
Relative humidity	5% to 90% noncondensing

## Storage Environment

Temperature	-55° to 125° C
Relative humidity	5% to 90% noncondensing

## Signal Connection

The following warnings contain important safety information concerning hazardous voltages and terminal blocks.

**Warnings:** *Avoid live circuits. To avoid electrical shock, do not remove equipment covers or shields unless you are qualified to do so. If signal wires are connected to the SCB-100, dangerous voltages may exist even when the equipment is turned off. Before removing the cover, disconnect the AC power or any live circuit from the terminal block.*

*The chassis ground terminals on your SCB-100 are for grounding high-impedance sources such as a floating source (1 mA maximum). Do not use these terminals as safety earth grounds.*

*Do not connect high voltages ( $\geq 42$  Vrms). National Instruments is not liable for any damages or injuries resulting from improper use or connection.*

To connect the signal to the SCB-100, perform the following steps:

1. Disconnect the 100-pin cable from the SCB-100, if connected.
2. Remove the grounding screws on either side of the top cover with a Philips-head #1 screwdriver. Open the top cover.
3. Configure switches to the signal types you are using, as explained in this guide.
4. Adjust the strain-relief hardware.
  - Loosen the strain-relief screws with a Philips-head #2 screwdriver and slide the signal wires through the front panel strain-relief opening.
  - If you are connecting multiple signals, remove the top strain-relief bar.

5. Add insulation or padding if necessary.
6. Connect the wires to the screw terminals by stripping 1/4 in. of insulation, inserting the wires into the green terminals, and tightening the screws.
7. Reinstall strain-relief (if removed) and tighten the strain-relief screws.
8. Close the top cover.
9. Reinsert the grounding screws to ensure proper shielding.
10. Connect the terminal block to the 100-pin connector.

## **Removing the Board**

You can remove the board from its housing to solder components into place. To remove the board, perform the following steps:

1. Disconnect the 100-pin cable from the SCB-100, if connected.
2. Remove the grounding screws on either side of the top cover with a Philips-head #1 screwdriver.
3. Open the top cover.
4. Loosen the strain-relief screws with a Philips-head #2 screwdriver.
5. Remove the signal wires from the screw terminals.
6. Remove the board mount screws and 100-pin connector screws.
7. Tilt the board up and pull it out of the enclosure.

Figure 5 shows the SCB-100 terminal block parts locator diagram.

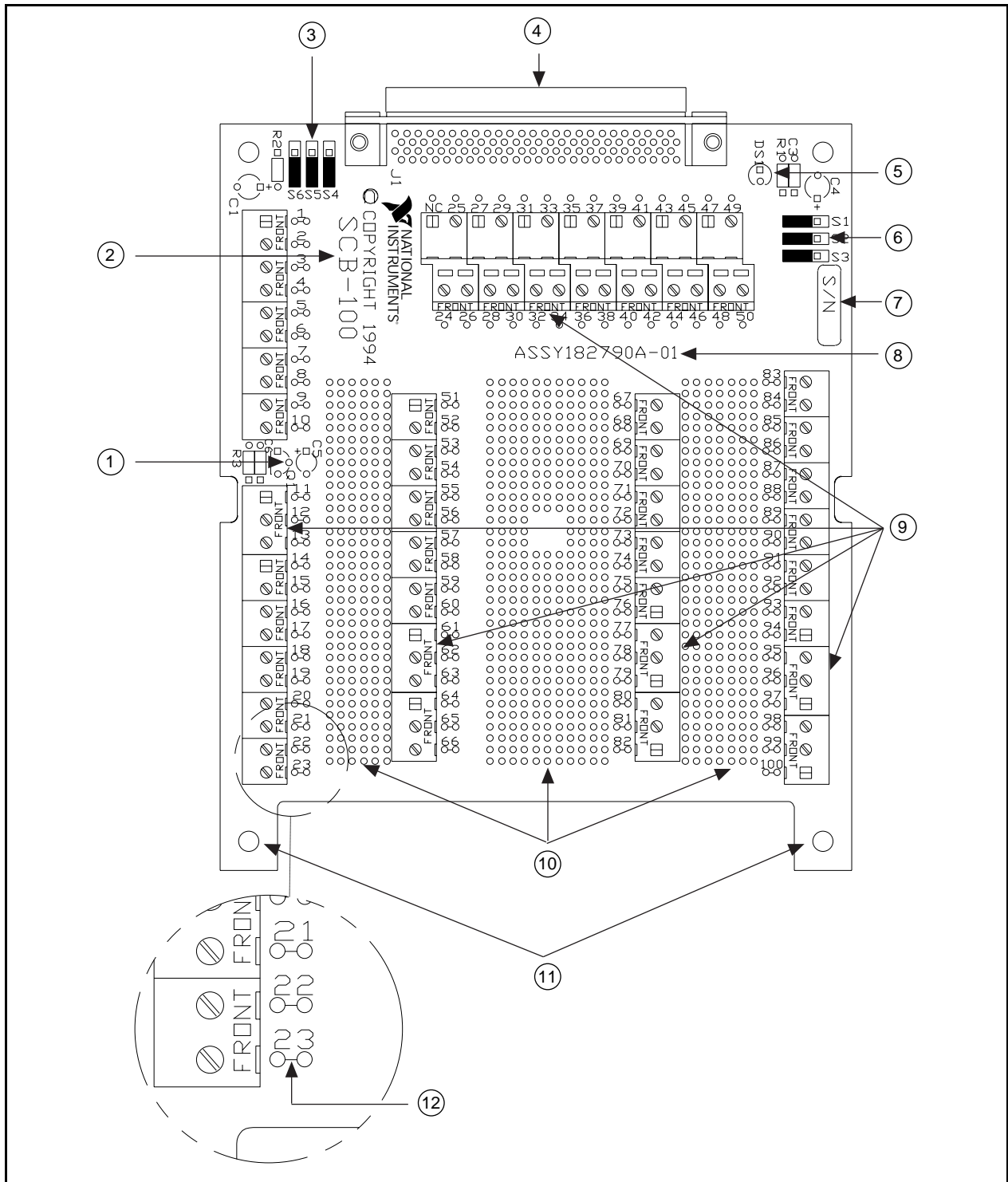

1 Cold-Junction Compensation Temperature Sensor	7 Serial Number
2 Product Name	8 Assembly Number
3 Switches S4, S5, and S6	9 Screw Terminals
4 100-Pin I/O Connector	10 Breadboard Area
5 Signal Accessory Power LED	11 Board Mount Screws
6 Switches S1, S2, and S3	12 Jumper Trace (cut to disconnect)

Figure 5. SCB-100 Terminal Block Parts Locator Diagram

## **Application Hints**

### **Soldering, Desoldering, and Cutting Jumpers on the SCB-100 Board**

The applications discussed here require you to make modifications to the printed circuit board, usually in the form of adding components or cutting jumpers. Use a low-wattage soldering iron (20 to 30 W) when soldering to the board.

To desolder on the SCB-100, vacuum-type tools work best. Use care when desoldering to avoid damaging component pads.

Use only rosin-core, electronic-grade solder. Acid-core solder damages the printed circuit board and components.

To make signal modifications easier, jumper traces are located next to each analog screw terminal. These jumper traces can be cut to disconnect the signal from the screw terminal, allowing resistor insulation for filtering. Refer to Figure 5 for more detail.

### **Connecting Nonreferenced or Floating Signal Sources**

This section applies when the SCB-100 is used in conjunction with an analog input board such as the MIO-16D or MIO-64.

A floating signal source is a signal source that is not connected in any way to the building ground system but has an isolated ground-reference point. If an instrument or device has an isolated output, that instrument or device falls into the floating signal source category. Some examples of floating signal sources are outputs for the following: thermocouples, transformers, battery-powered devices, optical isolators, and isolation amplifiers. The ground reference of a floating source must be tied to the ground of the data acquisition (DAQ) board to establish a local or onboard reference for the signal. If this reference is not established, erratic readings from the board will occur.

### **Differential Inputs**

To provide a return path for the instrumentation amplifier bias currents, floating sources must have a 10 to 100 k $\Omega$  resistor to the AIGND signal line on one input if DC-coupled, or both inputs if AC-coupled. For more detailed information on connections to floating signal sources and differential inputs, refer to the configuration chapter in your MIO board user manual.

### **Single-Ended Inputs**

When measuring floating signal sources, configure the MIO board to supply a ground reference. Therefore, configure the MIO board for referenced single-ended input. In this configuration, the negative input of the MIO board instrumentation amplifier is tied to the analog ground. For



more detailed information on connections to floating signal sources and single-ended inputs, refer to the configuration chapter in your MIO board user manual.

## **Connecting Ground-Referenced Signal Sources**

A grounded signal source is connected in some way to the building system ground; therefore, the signal source is already connected to a common ground point with respect to the DAQ board (assuming the host computer is plugged into the same power system). Nonisolated outputs of instruments and devices that plug into the building power system fall into this category.

### **Differential Inputs**

If the MIO DAQ board is configured for differential inputs, ground-referenced signal sources connected to the SCB-100 board do not require special components added to the SCB-100 board. For more detailed information on connections to ground-referenced signal sources and differential inputs, refer to the configuration chapter in your MIO board user manual.

### **Single-Ended Inputs**

When measuring ground-referenced signals, the external signal supplies its own reference ground point, and the MIO board should not supply one. Therefore, configure the MIO board for nonreferenced, single-ended input mode. In this configuration, all of the signal grounds should be tied to AISENSE, which connects to the negative input of the instrumentation amplifier on the MIO board. Referencing the signal to AIGND can cause inaccurate measurements resulting from an incorrect ground reference. For more detailed information on connections to ground-referenced signal sources and single-ended inputs, refer to the configuration chapter in your MIO board user manual.

## **Using the SCB-100 Board for Thermocouple Measurements**

The maximum voltage level generated by thermocouples is typically a few millivolts. Therefore, for best resolution, use an MIO board with a high gain.

Thermocouples can be measured in either differential or single-ended configurations. The differential configuration has better noise immunity, but the single-ended configuration has twice as many inputs. The MIO board must have a ground reference because thermocouples are floating signal sources. Therefore, you must install bias resistors if the MIO board is in differential mode. For single-ended configuration, use the referenced single-ended input configuration.

Cold-junction compensation with the SCB-100 board is accurate only if the temperature sensor reading is close to the actual temperature of the screw terminals. Therefore, when reading thermocouples, keep the SCB-100 board away from drafts or other temperature gradients such as those caused by heaters, radiators, fans, and warm equipment.

## Optional Input Filtering and Broken Thermocouple Detection

To reduce noise, you can build a simple RC lowpass filter in the breadboard area.

Build broken thermocouple-detection circuitry by connecting a high-value resistor between the positive input and +5 V. The value of this resistor is relatively unimportant; a few megaohms or more works fine. You can detect an open or defective thermocouple with a high-value resistor. If the thermocouple opens, the voltage measured across the input terminals rises to +5 V, a value much larger than any legitimate thermocouple voltage. The 100 k $\Omega$  resistor between the negative input and AIGND is a bias current return path as described in the *Connecting Nonreferenced or Floating Signal Sources* section earlier in this guide.

## Sources of Error

When making thermocouple measurements with the SCB-100 board and an MIO board, the possible sources of error are compensation, linearization, measurement, and thermocouple wire errors.

*Compensation error* can arise from two sources: inaccuracy of the temperature sensor, and temperature differences between the sensor and the screw terminals. The sensor on the SCB-100 board is specified to be accurate to  $\pm 0.5^\circ\text{C}$ . Minimize temperature differences between the sensor and the screw terminals by keeping the SCB-100 board away from drafts, heaters, and warm equipment.

*Linearization error* is a consequence of the polynomials being approximations of the true thermocouple output. The linearization error depends upon the degree of polynomial used.

*Measurement error* is the result of inaccuracies in the MIO board, including gain and offset. If the MIO board is properly calibrated, the offset error should be zero. The only remaining error is a gain error of  $\pm 0.08\%$  of full range (see your MIO board specifications). If the input range is  $\pm 10\text{ V}$  and the gain is 500, gain error contributes 0.0008 by 20 mV, or 16  $\mu\text{V}$  of error. If the Seebeck coefficient of a thermocouple is 32  $\mu\text{V}/^\circ\text{C}$ , this measurement error adds  $0.5^\circ\text{C}$  of uncertainty to the measurement. For best results, use a well-calibrated MIO board so that offsets can be ignored. Eliminate offset error by grounding one channel on the SCB-100 board and measuring the voltage. This value, the offset of the MIO board, can then be subtracted by software from all other readings.

*Thermocouple wire error* is the result of inconsistencies in the thermocouple manufacturing process. These inconsistencies, or nonhomogeneities, are the result of defects or impurities in the thermocouple wire. The errors vary widely depending on the thermocouple type and even the gauge of wire used, but a value of  $\pm 2^\circ\text{C}$  is typical. For more information on thermocouple wire errors and more specific data, see the *Manual on the Use of Thermocouples in Temperature Measurement*, ASTM/Special Publication 470A, Omega Press, Stamford, CT 06907, 1974.

For best results, use an average of at least 100 readings to reduce the effects of noise.